

# Wastewater

## WSV50H Series



**WSV50HAM**



**WS50HM**

### Applications

- Ideal for handling raw sewage as well as commercial dewatering sump applications with up to 3/4" solids.

### Features

- 1/2 hp powerful 115 Volt, oil free PSC motor. Rated for continuous duty, with thermal overload protection and double ball bearings for reliability
- Motor housing, pump volute and impeller are cast iron
- 2" NPT discharge
- A high capacity cast iron vortex impeller, designed for superior solids handling capabilities. This impeller is able to pass 3/4" solids by creating a vortex. This provides superior clog free operation
- Carbon ceramic mechanical seal
- 300 Series stainless steel shaft for corrosion resistance
- 304 Series stainless fasteners throughout, for serviceability
- Mechanical piggyback float switch for automatic on-off operation
- 20' power cord sealed at motor housing



## Engineering Data

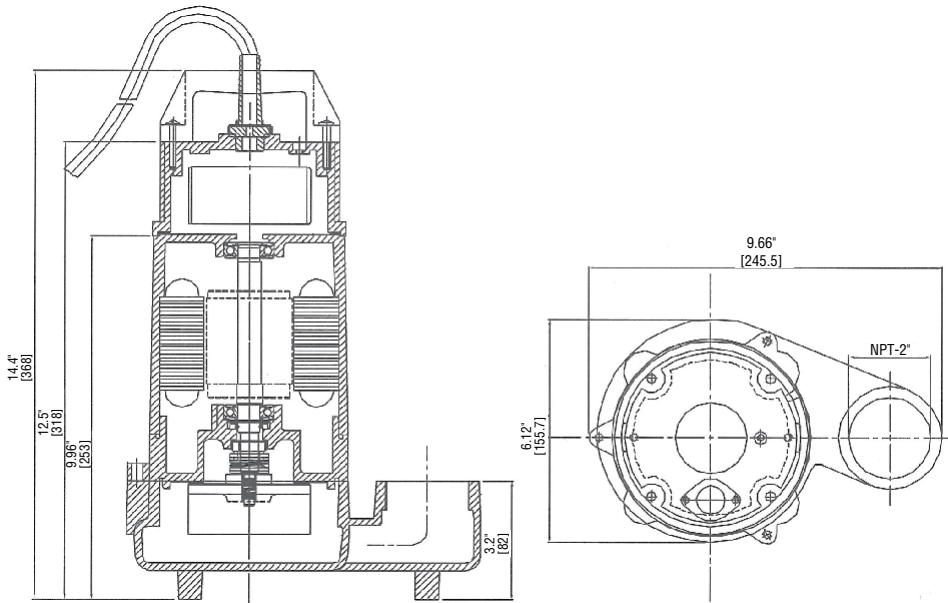

\*Dimensions measured in inches [mm]

## Specifications

Item No.	Model No.	Listing	HP	Volts	Discharge	Performance (gpm @ head)					Shut-Off Head (ft)	Cord Length (ft)	Ship Wt. (lbs)
						20'	25'	30'	35'	40'			
620238	WSV50HM	cCSAus	1/2	115	2" NPT	83	74	62	48	30	45	20	36
620239	WSV50HAM	cCSAus	1/2	115	2" NPT	83	74	62	48	30	45	20	38

## Performance Data

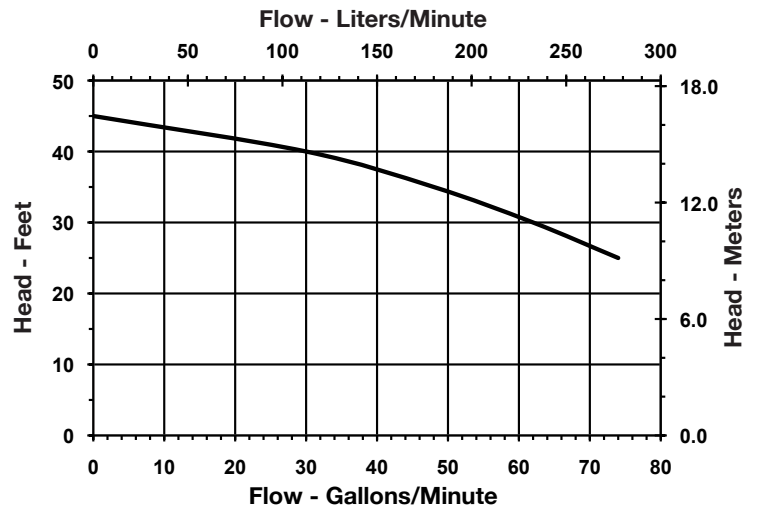

**Franklin Electric**

P.O. Box 12010  
 Oklahoma City, OK 73157-2010  
 Phone: 1.800.701.7894  
 Fax: 1.800.678.7867  
[www.LittleGiantPump.com](http://www.LittleGiantPump.com)

©2011 Franklin Electric Co., Inc.  
 Little Giant® is a registered trademark of Franklin Electric Co., Inc.  
 Form 996173 — 05/11